

PROPEL KIT

FOR SAFETY: Before installing kit, turn machine off and disconnect battery cable!

#1. CABLE BRACKET EXCHANGE INSTRUCTION:

STEP 1: Remove (old) cable fixture bracket. First remove bowden cable fixture screws (a) then remove bracket fixture screws (b)

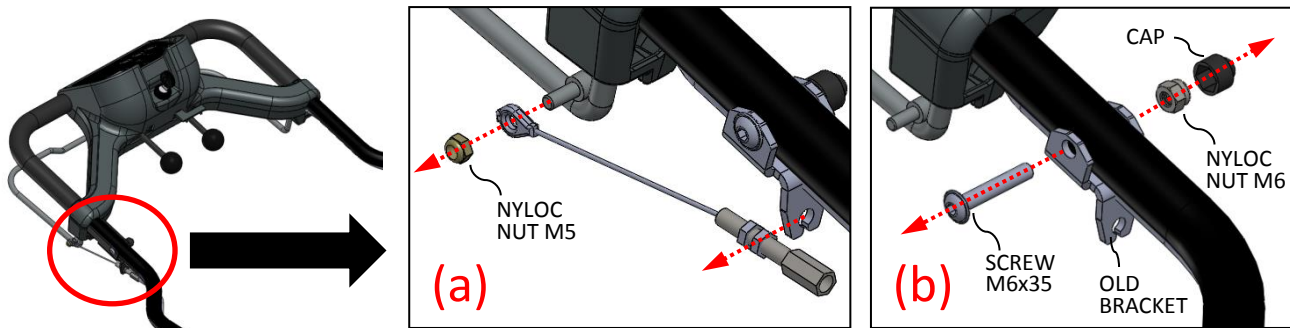

STEP 2: Throw away old cable bracket (a). Then install new cable bracket (b) and reinstall cable (c)

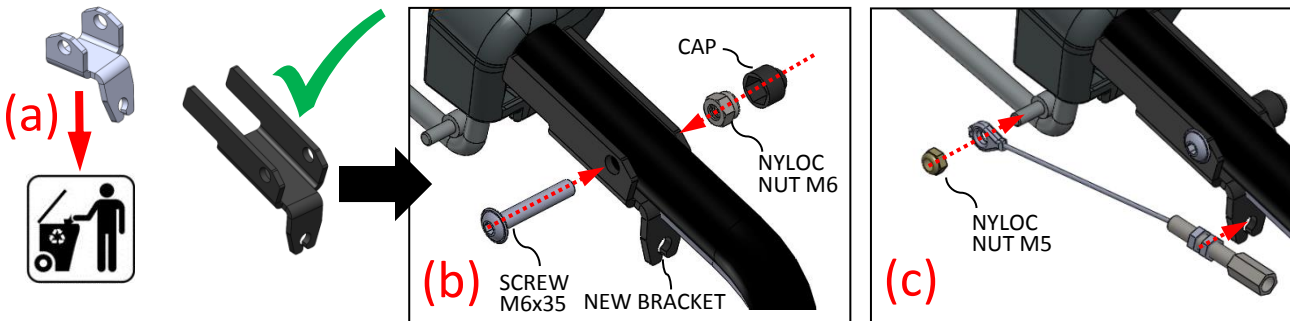

#2. BELT TENSIONER - FASTENER EXCHANGE INSTRUCTION:

STEP 1: Remove the cable retaining collar (a) and the cable (b) from the pin.

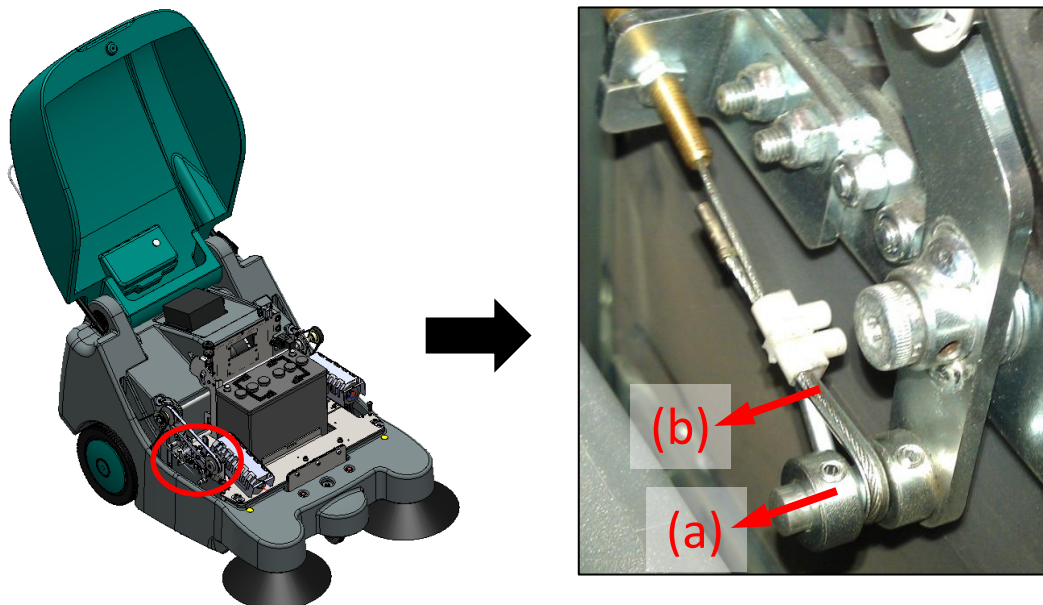

STEP 3: Loosen the screws on the clamp (a) and move the clamp to increase the loop size (b). Insert the thimble into the loop (c), fix it by moving back the clamp (d) and tighten the screws (e).

 Take care that total length of cable will not be modified

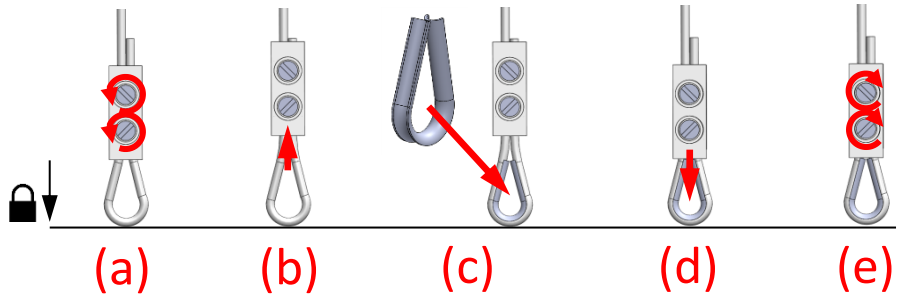

STEP 4: Replace the belt-tensioning arm with new arm. Use fasteners included in kit (a) as shown. Then place the cable / thimble on the pin (b) and fix it with the retainer collar (c).

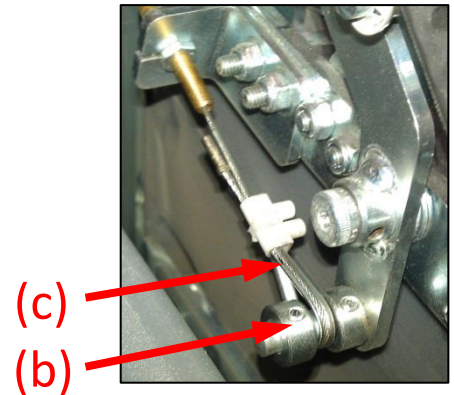
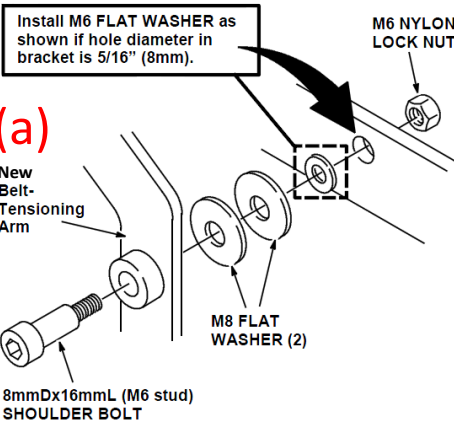
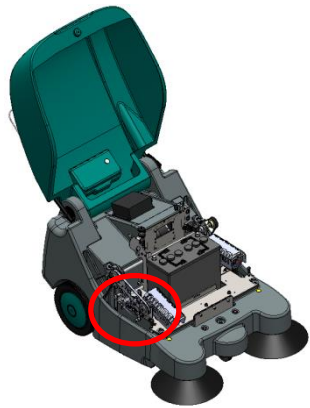

#3. SPRING ASSEMBLY INSTRUCTION:

First connect the spring to the metal base (a) and then connect it to the belt tensioning arm (b).

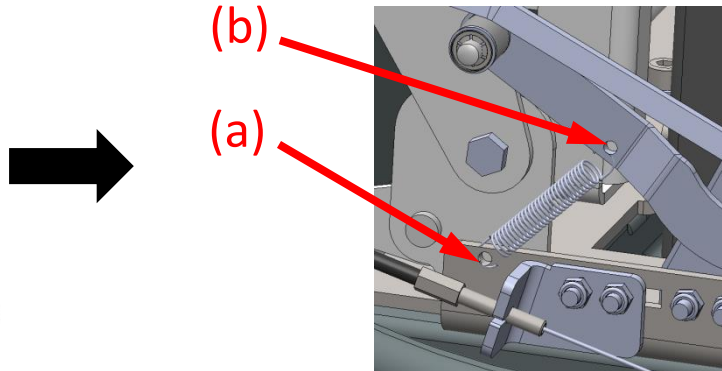
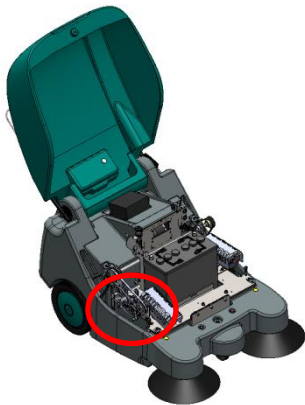

#4. CABLE ADJUSTMENT INSTRUCTION:

After installing the new kit parts, adjust the bail at points A and B for proper bail operation. For proper adjustment, the machine should begin to propel forward when bail is slightly squeezed.

